

DDK Ltd.

**CM10-AP××S-x(D6)
Angle Plug Connector
(Weight saving type · Soldering type)
Cable Assembly Manual(Standard Type)**

Date of Issue: February 16, 2009

Material No. TC-606

DDK Ltd.
2ND Production engineering department assembly group
14 Matsuyama-cho, Moka-shi, Tochigi
TEL : 0285-82-4463

Revision	Date	Revision No.
A	2/16/09	New Issue
B	22/Jul/'11	T-2692

Material No.	Page
TC-606	1/11

Contents

	Page
1. Outline	2
2. Specifications	2
2-1. Applicable connector	2
3. Cable Assembly Process	2
3-1. Cutting a cable	2
3-2. Stripping a cable sheath	2
3-3. Inserting parts.....	3
3-4. Stripping a core wire	3
3-5. Soldering a contact.....	4
3-6. Inserting a contact	5
3-7. Tightening an angle back shell.....	6
3-8. Inserting a bushing and a cable clamp.....	8
3-9. Tightening a clamp nut	9

1. Outline

This Cable Assembly Manual explains how to assemble the wire to the CM 10 angle plug connector.
(Solder type)

2. Specifications

2-1. Applicable connector

Connector name	Drawing number
CM10-AP2S-S(D6)	115J-AP12162-1
CM10-AP2S-M(D6)	115J-AP12162-2
CM10-AP2S-L(D6)	115J-AP12162-3
CM10-AP10S-S(D6)	115J-AP12160-1
CM10-AP10S-M(D6)	115J-AP12160-2
CM10-AP10S-L(D6)	115J-AP12160-3

3. Cable Assembly Process

3-1. Cutting a cable

Cut the cable to the following dimensions:

Note! Not to change cable length.

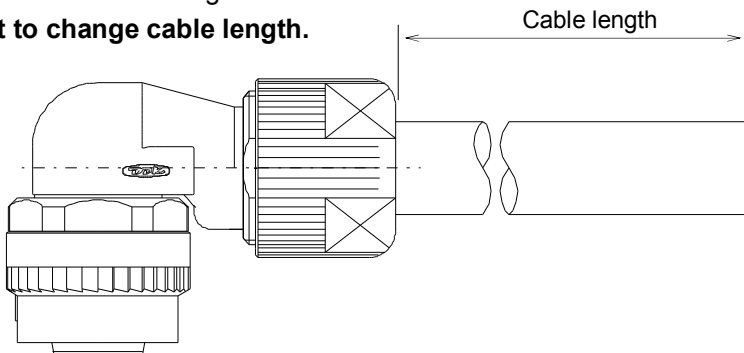

*Cable length after cutting = measurement A for CM10-APxxS(D6) + Cable length
= A + Cable length

Product name	A length
CM10-AP XX S-S(D6)	40±0.5mm
CM10-APXX S-M(D6)	
CM10-AP XX S-L(D6)	

3-2. Stripping a cable sheath

Strip the cable sheath to the length A as shown below.

Note! Take care the cable peel length.

Take care not to damage anything.

* **When making CM10-AP10S(D6), strip the cable for No. 10 terminal in a way that makes the A length 1mm longer than other cables. (To avoid the cable tension when inserting a contact to the housing in a later process.)**

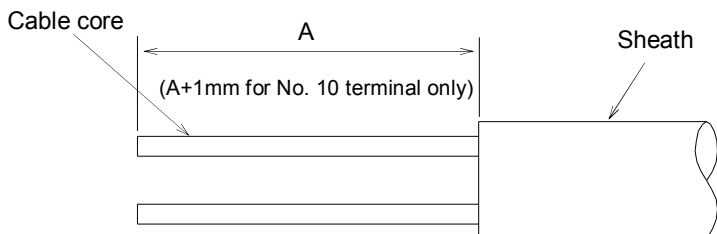

Product name	A length
CM10-AP XX S-S(D6)	30±0.5mm
CM10-APXX S-M(D6)	
CM10-AP XX S-L(D6)	

3-3. Inserting parts

Insert the clamp nut, the cable clamp, the bushing and the angle back shell to the cable stripped.

Note! Pay attention to the direction each part is inserted.

Make sure that every part is inserted.

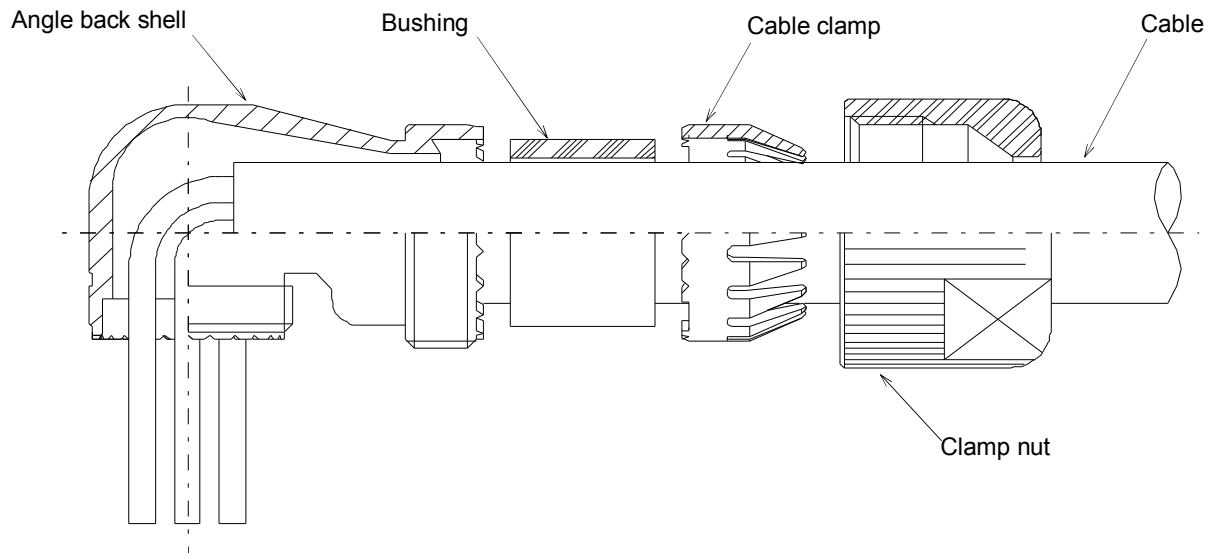

*** To insert the angle back shell, bend the cable.**

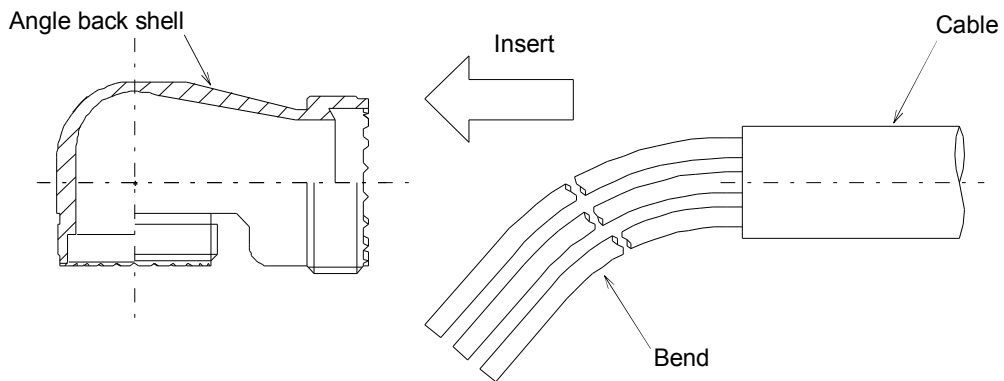

3-4. Stripping a core wire

Strip the cable's core wire to the length 4.5 to 5.0mm.

Note! Do not mistake the length of the core wire to be stripped.

Do not leave cut or scratch to the cable core.

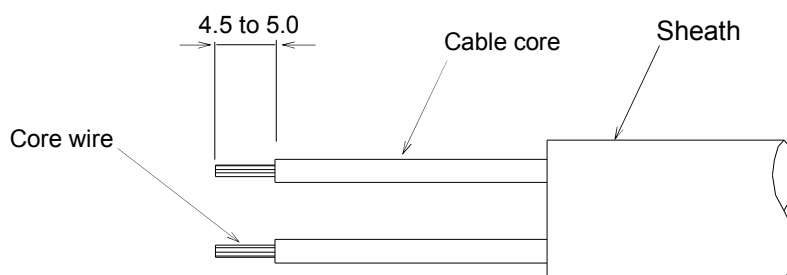

3-5. Soldering a contact

Apply preliminary soldering to each contact and to the cable's core wire, then solder the core wire to the contacts.

Contact name	Applicable contact	Applicable cable
CM10-AP10S-X(D6)	CM10-#22SC(S1)(D8)	AWG20 or below
CM10-AP2S-X(D6)	CM10-#22SC(S2)(D8)	AWG16 or below

Note! Make sure that the core wire does not come out of the contact.

When soldering, make sure that the solder does not stick to the circumference of the solder cup.

When using a drain wire, attach a heat shrink tube to the drain cable after soldering.

* When making CM10-AP10S(D6), the cable for No. 10 terminal is 1mm longer than other cables. (To avoid the cable tension when inserting a contact to the housing in a later process.)

* The difference in the total A length of the cables for other than No. 10 terminal must be 1mm or less.

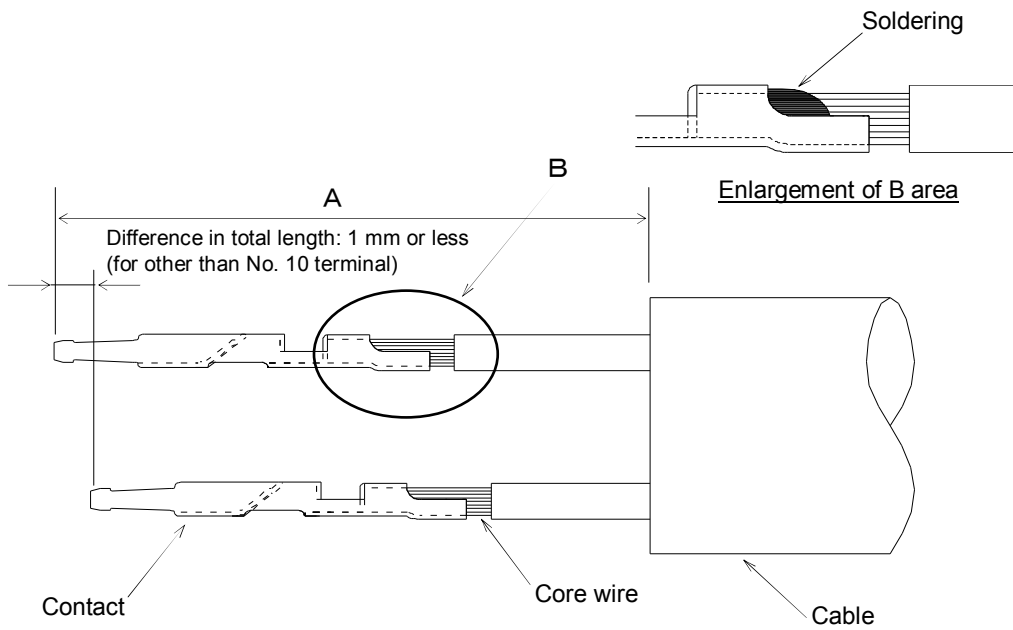

Product name	A length
CM10-AP × × S-S(D6)	39 to 42mm
CM10-AP × × S-M(D6)	
CM10-AP × × S-L(D6)	

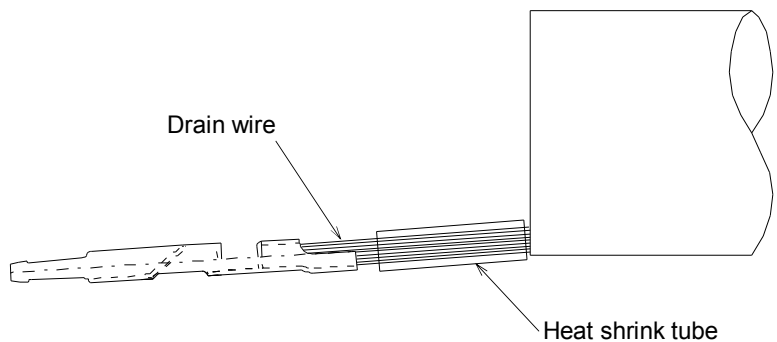

If a drain wire is soldered

3-6. Inserting a contact

Insert the contact into the specified terminal number point in the housing.
(Insert grounding wire or drain wire into terminal No. 10).

- * **When the contact catches the housing, you will hear a snap.**
- * **Pulling the wire for confirming the correct position.**

Note! Before inserting the contact, check that the clamp nut, cable clamp, bushing and angle back shell is inserted.

Take care not to insert the contact upside down as shown below.

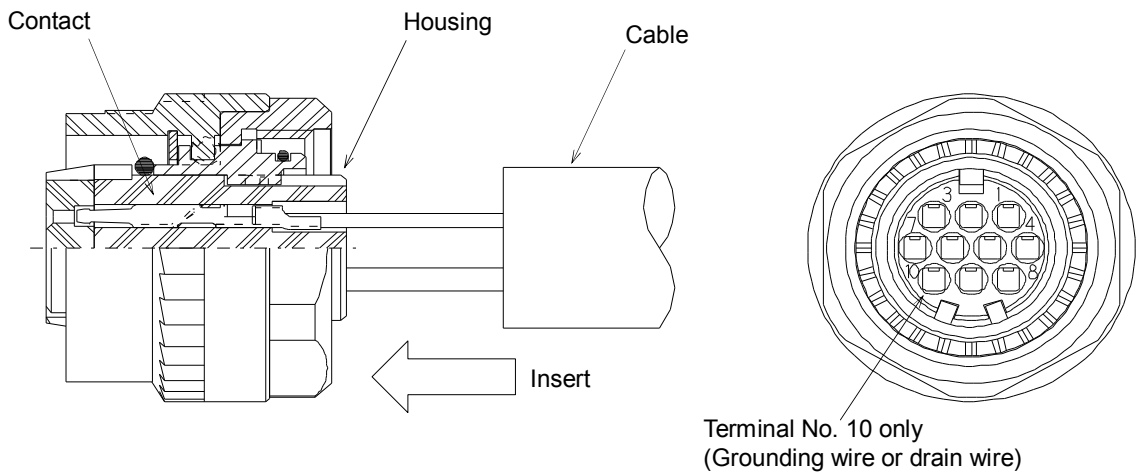

- * **Insert the contact so that the terminal number face the same direction.**
However, in case of CM10-AP2S(D6), insert the contact so that the lance and the terminal number face the opposite direction.

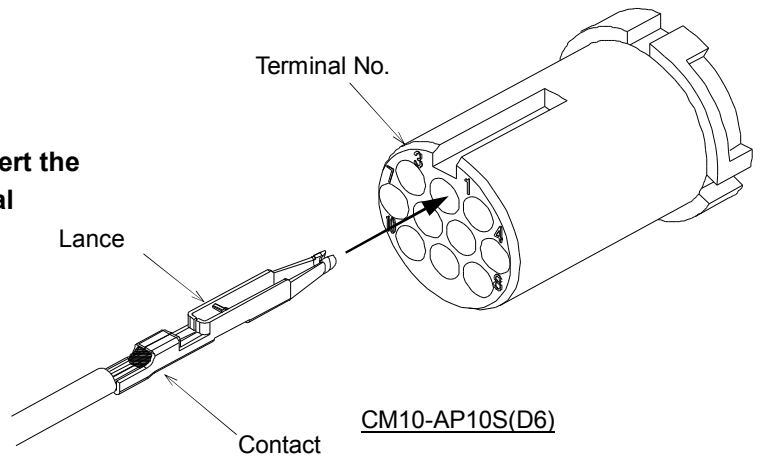

- * **Using a pull out tool for pulling up inserted contact.**
Tool No.: 357J-50548T

Refer to the instruction manual in case of using pull up tool.

- * **As Lance falls down easily after pulling up, set up to original position before re-insert.**

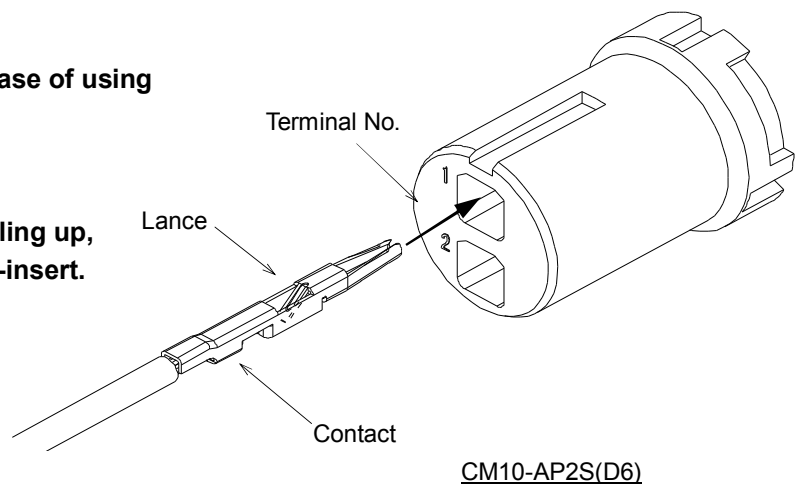

3-7. Tightening an angle back shell

- (1) To prevent loosening, the adhesive should be applied to the angle back shell by two threads around the circumference.
 - Recommended adhesive: 1401B (Three Bond Co., Ltd.)
- (2) Rotate and temporarily tighten the back shell coupling by setting the connector and the angle back shell to the specified angle.

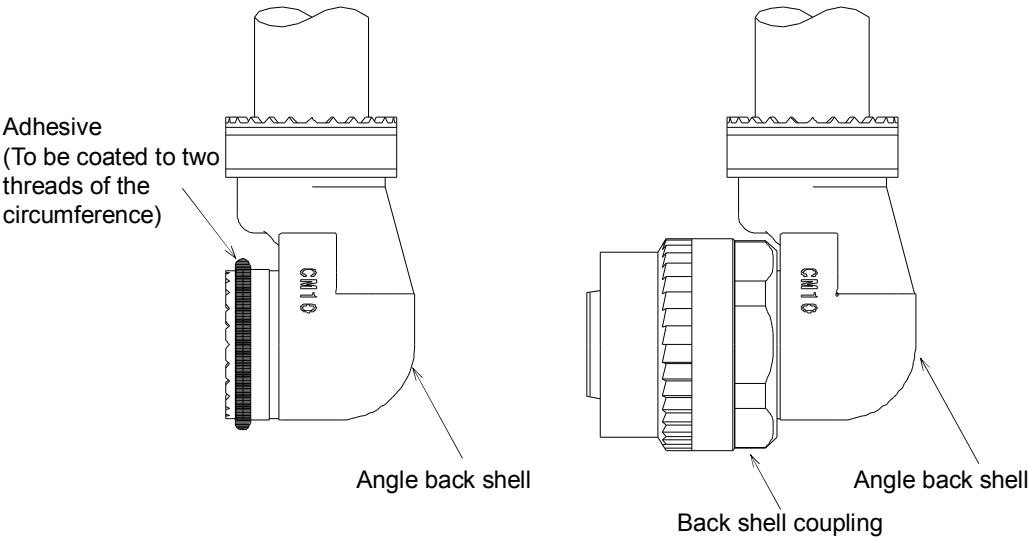

***When tightening temporarily, match the concavity and convexity of the plug shell with those of the angle back shell.
 (You can confirm the correct connection of concavity and convexity waving lightly back shell just before inserting to BS coupling.)**

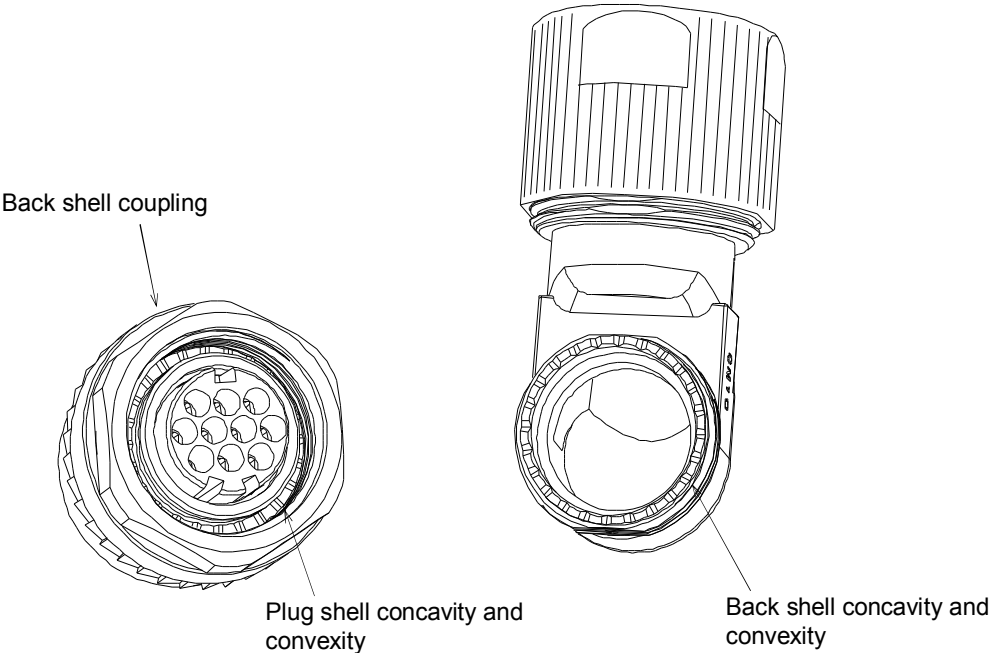

- (3) Fix the 2 surface width of the angle back shell on the tightening guide.
- (4) Set the back shell wrench adjusting to the 2 surface width of the back shell coupling.
- (5) With the wrench, tighten the back shell coupling to the angle back shell.
Recommended tightening torque: 5N·m

**Note! When setting the work to the wrench, adjust it to the 2 surface width.
To remove, take the reverse steps.**

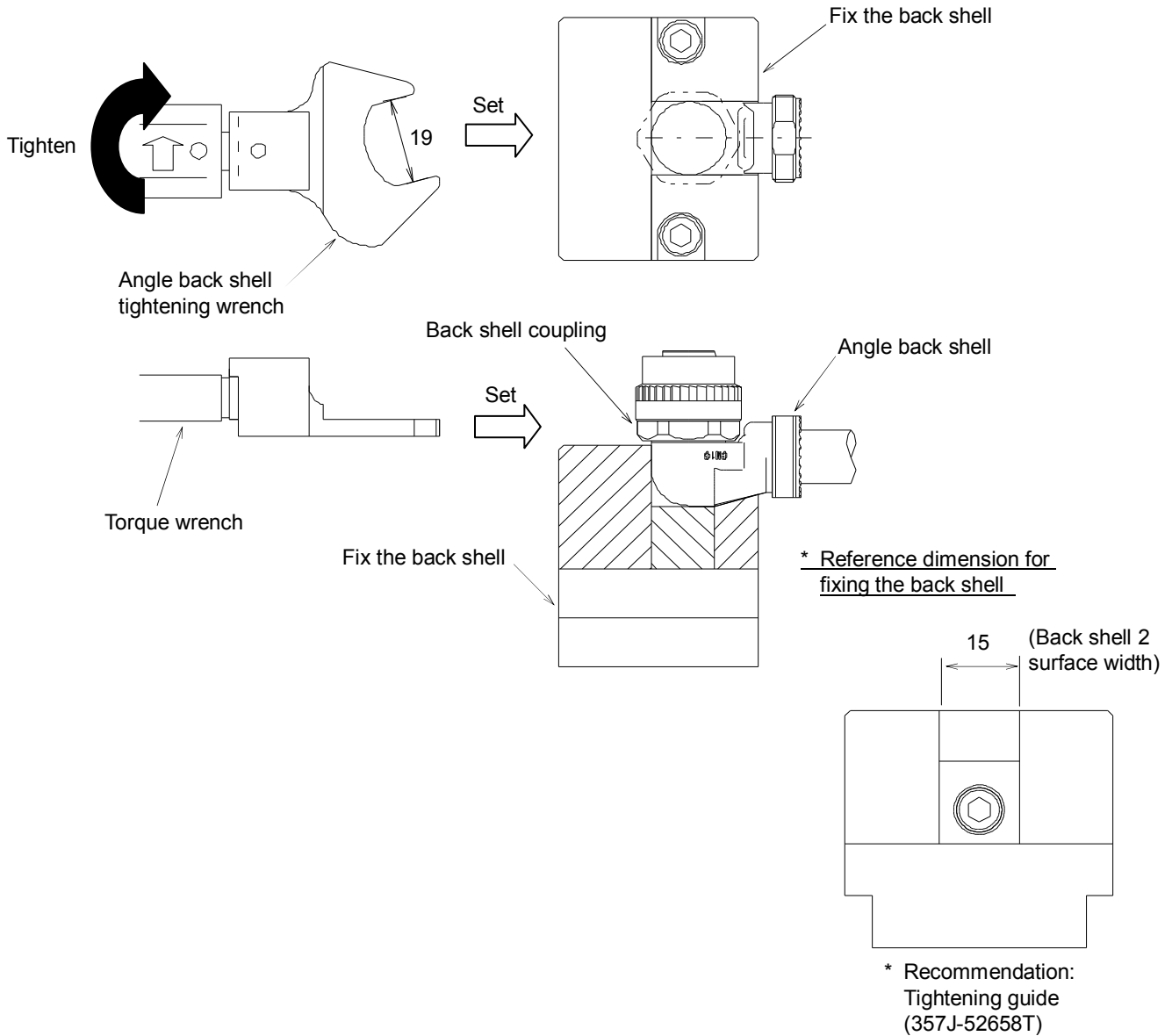

Note! To change the angle of the back shell, do it by changing the engaging position of the concavity and convexity of the plug shell and the back shell.

- Recommended jigs and tools : Back shell wrench (357J-51333T)
 Bit (357J-51344T)
 Torque wrench (CL6N x 8D), Tonichi Mfg.)
 * Recommended tightening guide: (357J-52658T)

3-8. Inserting a bushing and a cable clamp

Insert the bushing and the cable clamp to the back shell.

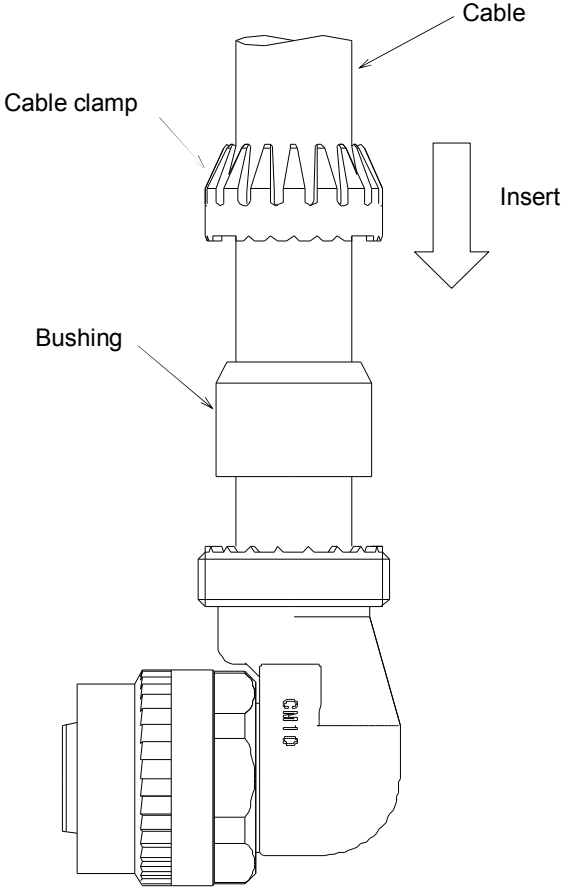

Note! After the Bushing insert, confirm that cable position should be inside of Bushing.

3-9. Tightening a clamp nut

(1) Temporarily tighten the clamp nut on the angle back shell.

***To prevent loosening, the adhesive should be applied to the angle back shell.**

● **Recommended adhesive: 1401B (Three Bond Co., Ltd.)**

(2) Fix the 2 surface width of the angle back shell on the tightening guide.

(3) Set the tightening wrench adjusting the 2 surface width of the clamp nut.

(4) With the wrench, tighten the clamp nut on the angle back shell.

Recommended tightening torque: 5 N·m

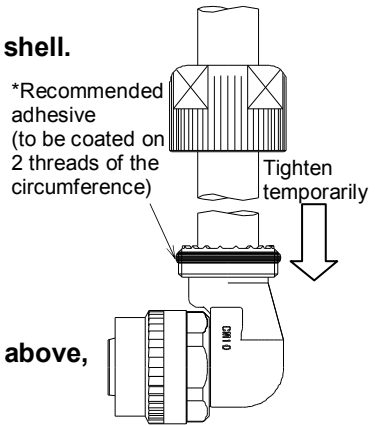

Note! To set the work to the wrench, adjust the 2 surface width.

In case of squeezing the clamp nut with excess torque provided as above, the clamp nut may be broken. Please use the torque wrench.

To remove, take the reverse steps.

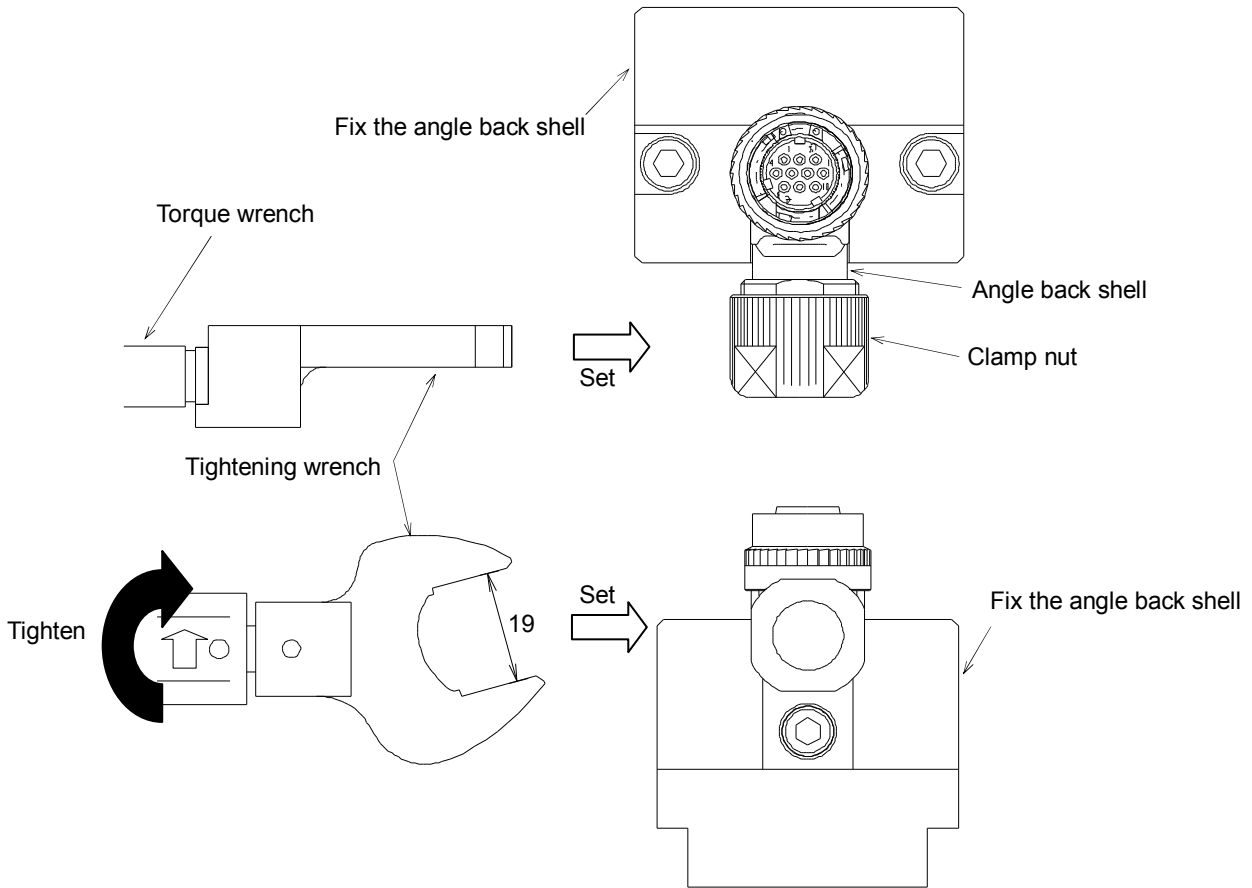

* Reference dimension for fixing the back shell

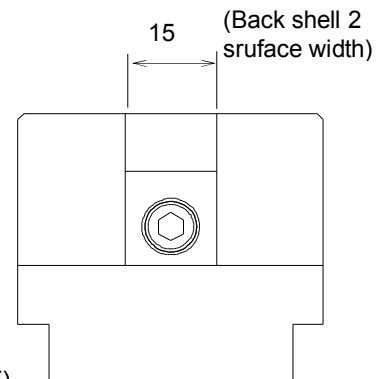

- Recommended jigs and tools : Clamp nut wrench (357J-51334T)
 Bit (357J-51345T)
 Torque wrench (CL6N×8D, Tonichi Mfg.)
 * Recommended tightening guide :(357J-52658T)

* Recommendation:
Tightening guide
(357J-52658T)

***To connection**

(1) Set the Δ mark of each other's connectors.

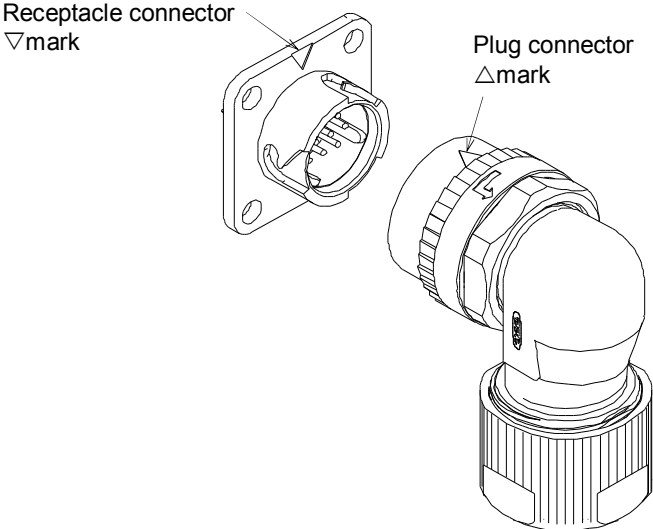

(2) Each other's key (concavity and convexity) are fit in. Push it straight, take care not to tilt.

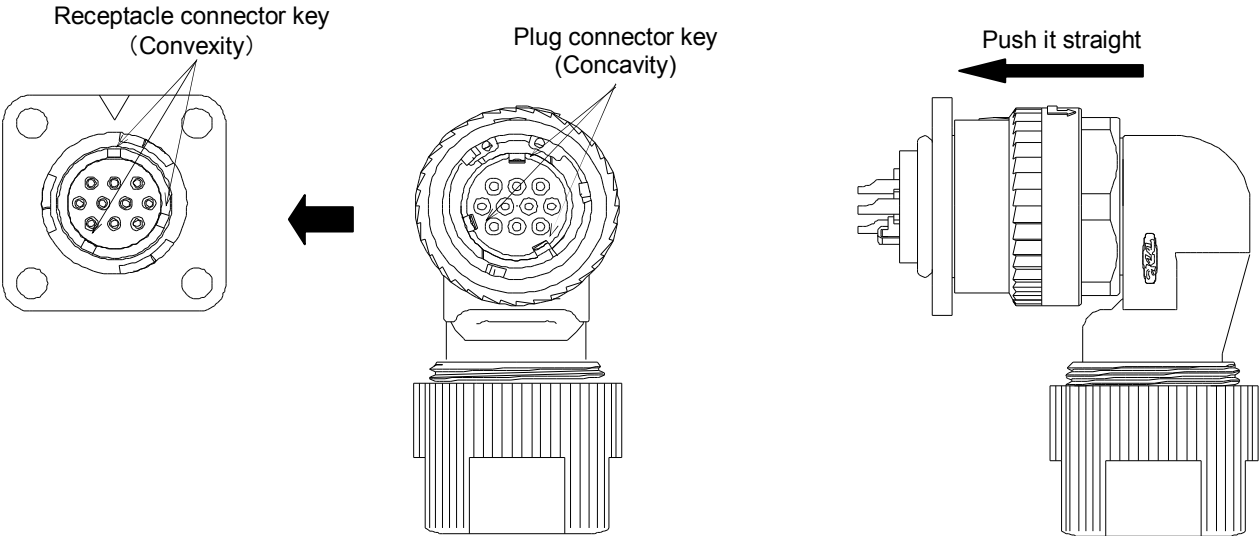

***To remove, rotate the coupling and pull out to straight.**

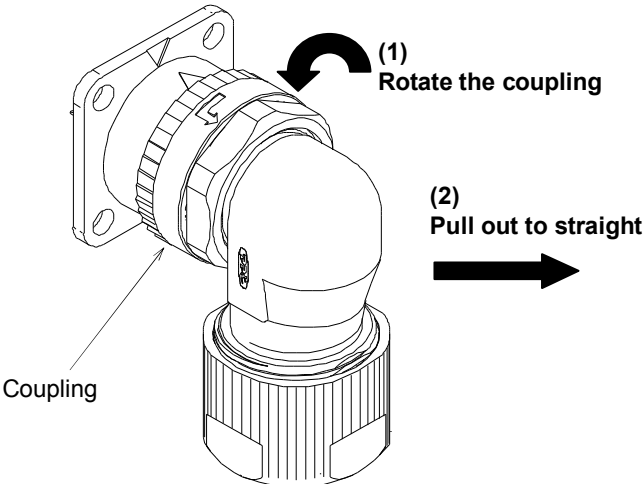

*When using a conduit

- (1) Tighten the nipple of conduit connector on the plug connector (CM10).
- (2) Set the conduit on the nipple of conduit connector.
- (3) Fix the conduit to the plug connector (CM10). If the conduit is used in a moving part, fix the conduit with a saddle, etc. so that no load is applied to the plug connector (CM10) and to the conduit connector. If the conduit is fixed with a saddle, etc., make sure that no load is applied to the fixing area. Set the protective cover (rubber etc.) on the conduit to avoid cable damage.

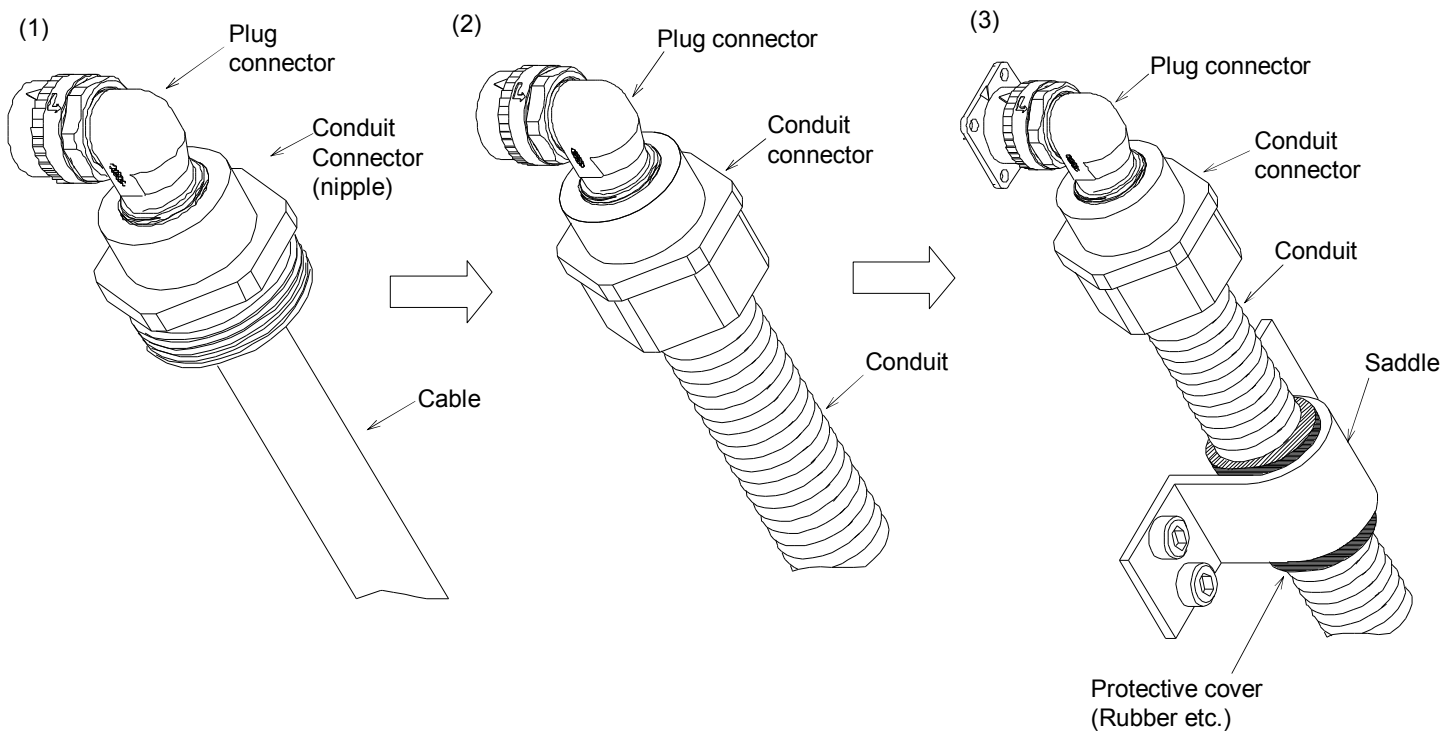

● Recommended conduit & connector : NIPPON FLEX CO.LTD

- Conduit
- Tipe:VF Tipe:SR Tipe:FBN Tipe:EM
- Tipe:VFS Tipe:SRK etc.,
- Connector
- Tipe:RCM

* NIPPON FLEX CO., LTD home page → <http://www.nipolex.co.jp>